



Toll Free: 1-800-579-8088 Web: www.zinko.com

MODEL
ZPE-73HS Series
Electric Pumps

Operation & Maintenance Manual

Safety Information

Read and follow all WARNINGS, CAUTIONS and INSTRUCTIONS included with each product to use the product correctly and to avoid personal injury or property damage during system operation. **ZINKO** will not be held responsible for damage or injury resulting from unsafe use of products, lack of maintenance or incorrect system application.

Caution Remarks Used In This Manual

- ⚠ DANGER** As a result of incorrect use and/or disregard of this remark, imminent danger may occur resulting in serious injury or death.
- ⚠ WARNING** As a result of incorrect use and/or disregard of this remark could cause serious injury or death.
- ⚠ CAUTION** As a result of incorrect use and/or disregard of this remark, there is a possibility that an operator may receive an injury or material damage may occur.

Cautions When Installing Pump

Install a pump unit for better balance

Since the reservoirs of totally enclosed rubber structures are used in these series of pumps, the pumps can be placed for use in any position (slanted, inverted, or perpendicular). However, the pumps should be installed on stable places. When a pump is used aslant, make sure it is firmly affixed to prevent sliding which may result in damage or personal injury.

Prepare a suitable working environment

Make sure all system components are protected from external sources of damage such as excessive heat, flame, moving machine parts, sharp edges, or corrosive chemicals.

⚠ CAUTION

1. DO NOT USE PUMP IN THE RAIN OR ON/IN WET AND DUSTY PLACES.
2. DO NOT EXPOSE HYDRAULIC SYSTEM TO THE DIRECT RAYS OF THE SUN. Be careful with unacceptable rise in hydraulic oil temperature, which can cause trouble in hydraulic equipment.
3. In the case pumps are used outdoors in extremely cold regions, exchange oil for hydraulic oil with the proper viscosity. Increased viscosity due to a drop in oil temperature may cause equipment to function improperly.

⚠ WARNING

1. BE CAREFUL TO AVOID ELECTRIC SHOCK. Do not pull power plug out with a wet hand. Use a grounded outlet or a plug adapter with a grounding attachment in order to protect the operator from electric shock.
2. DO NOT OPERATE PUMP BY THE SIDE OF AN ELECTRIC WELDER.
3. DO NOT PLACE THE PUMP ON EARTHED MATERIALS OR EQUIPMENT.

Using the Pump

Be Sure to Take Appropriate Safety Measures

When hydraulic equipment is operated, protect yourself with a personal safeguard, working clothes and shoes, safety glasses, etc.

Always Check Pressure Limitations of the Hydraulic Circuit

Always confirm in advance that maximum permissible working pressure of a hydraulic pump is lower than the pressure rating of the lowest rated component connected in the system.

Power Supply

The power supply is AC110V or 220V 50/60Hz single phase. Make sure your line voltage is compatible with your pump. The wrong voltage connection or voltage drop of your line will cause burning or heating.

⚠ CAUTION

1. BE CAREFUL ABOUT VOLTAGE DROP WHEN USED WITH AN ELECTRIC GENERATOR.
2. When the power supply is disconnected, ALWAYS GRASP THE POWER PLUG AND PULL IT OUT. Disconnect by grasping the cord and pulling it out will cause breaking of a wire or a short circuit.
3. When a supplement cord is used, use only three-wire grounded cords of such sufficient gauge as 1.25mm² or more with a maximum length of 10M. This will help to avoid voltage drop or damage of the solenoid valves or the electric motor.

Zinko Hydraulic Jack

Model: ZPE-73HS Series

ZPE-73HS-7

#	Description
1	Electric Motor
2	Reservoir
3	Output Port: 3/8" NTP
5	4-Way Manual Valve
6	Pressure Switch
7	Pressure Gauge
8	Oil Filler
9	Power Switch
10	Oil Gauge

Model	Height
73	20 1/2"
153	20 1/2"
223	23 7/8"

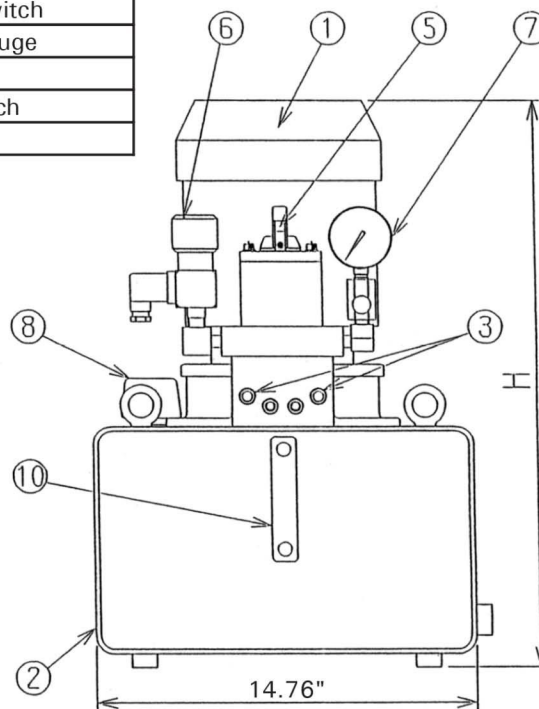
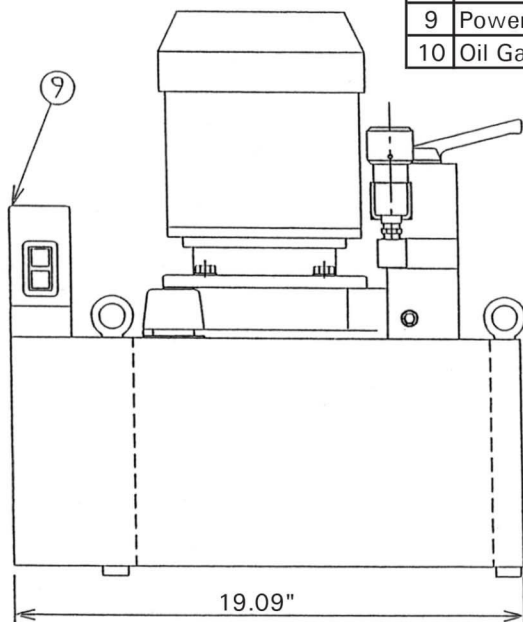

ZPE-73HS-8WP

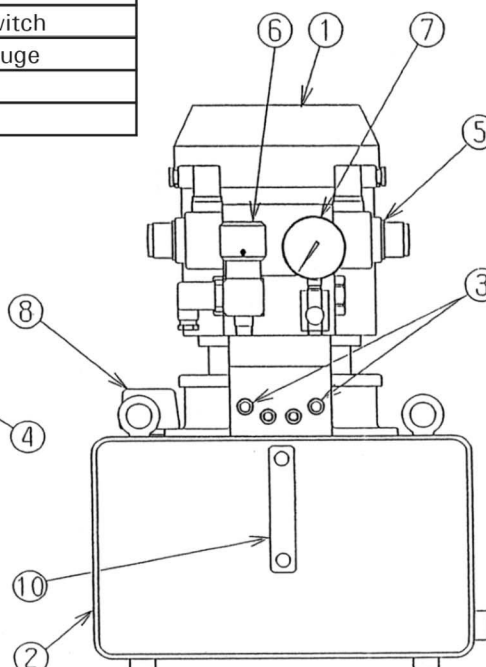
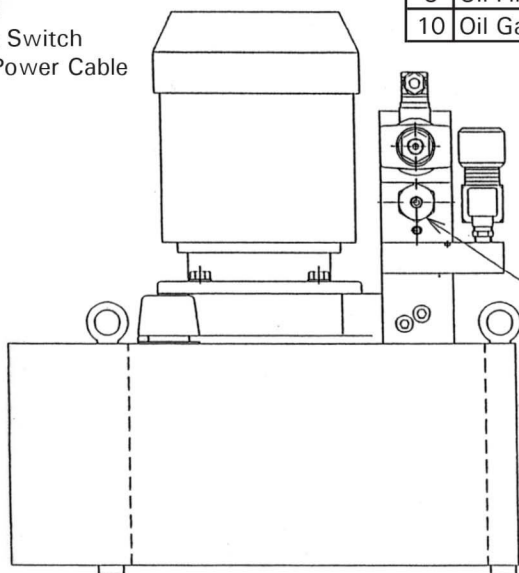
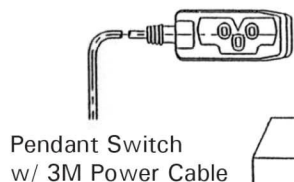

#	Description
1	Electric Motor
2	Reservoir
3	Output Port: 3/8" NTP
4	Pilot Check Valve
5	4-Way Manual Valve
6	Pressure Switch
7	Pressure Gauge
8	Oil Filler
10	Oil Gauge



Zinko Hydraulic Jack

Model: ZPE-73HS Series

Instructions Before Use

1. Inspect all components for shipping damage or oil leakage. If any shipping damage is found, notify carrier at once. Shipping damage is not covered by warranty. The carrier is responsible for all repair or replacement costs resulting from damage in shipment.
2.  **Oil feed plugs** are always shut tightly when in shipment and even in use. When the pump is used, turn this vent/fill plug cap by 1 to 2 turns counterclockwise to open/vent. Operation of the pump with this plug being closed may cause insufficient oil delivery or building up of pressure.
3.  **Check your power supply.** Power supply is AC110V or 220V 50/60Hz single phase. Make sure that a grounded outlet or a plug adapter with a grounding attachment is used.
4.  **Check hydraulic oil.** Always check oil level before operation with the connected cylinders fully retracted (extend if pull cylinders). In case oil is added with cylinders extended and then cylinders are retracted, the returned oil will overflow in the reservoirs causing generation of high pressure in the reservoirs. Verify required oil volume in a reservoir as follows:
 - a) Retract the connected cylinder fully.
 - b) Check the oil gauge and confirm that the gauge reads half. If oil is short (does not reach half of the gauge level) replenish oil (see *Maintenance* section).

Operation

ZPE-753HS Series for use with single-acting cylinders:

ZPE-753HS-0 with P.T. manifold, but without any operation valve.

1. Plug in the pump.
2. The P.T. manifold has a delivery port and return port. Depress "A" operation switch to run the motor pump to deliver oil. A remote mounted type operation valve is usually installed between the pump and cylinder in such an application as where the pump is far away from an operation position.

ZPE-753HS-1 with MVS-3 3-way manual valve.

1. Close release valve lever by turning clockwise (stop at 45°) and depress "A" switch to advance the cylinder.
2. To retract the cylinder, return the valve lever to the original (front) position.

ZPE-753HS-4 with 2-way normally closed solenoid valve.

1. Depress "A" switch to run the motor to advance the cylinder. If the "ON" switch is released, the motor stops and cylinder's piston remains stopped for pressure holding.
2. Depress "B" switch to retract the cylinder.

ZPE-753HS-2 with SVS-2H 2-way normally open solenoid valve. Advance/Auto Retract.

1. Depress "A" switch to run the motor to advance the cylinder.
2. Release "A" switch to stop the motor, and the cylinder retracts.

ZPE-753HS Series for use with double-acting cylinders:

ZPE-753HS-7 with MVS-4 4-way 3-position directional control manual valve. Advance/Hold/Retract.

1. Shift manual valve handle to left side position (stop at 45°) and depress "A" switch to advance the cylinder (Flow to port "B", port "A" returns flow to the reservoir). NOTE: Before retracting the cylinder, return valve handle to neutral (front) position (Both ports "A" and "B" are blocked).
2. Shift valve handle to right side position and depress "A" switch to retract the cylinder (Flow to port "B", port "A" returns flow to the reservoir).

ZPE-753HS-8SP/8WP with SVS-4H 4-way 3-position solenoid valve and VPCS-10 or VPCW-10 pilot-operated check valve. Advance/Hold/Retract.

1. Depress "A" switch to run the motor and to advance the cylinder (Flow to port "A", port "B" returns flow to the reservoir). The motor stops with "A" switch released.
2. Depress "B" switch run the motor and to retract the cylinder (Flow to port "B", port "A" returns flow to the reservoir). ZPE-45SVG-8SP pump allows pressure holding of port "A" by means of single pilot-operated check valve, while ZPE-45SVG-8WP can hold pressure on both ports "A" and "B" by pilot-operated check valves.

ZPE-753HS-8A with SVS-4A or SVS-4H 4-way 3-position solenoid valve. Advance/Retract.

1. Depress "A" switch to run the motor and to advance the cylinder (Flow to port "A", port "B" returns flow to the reservoir). The motor stops with "A" switch released.
2. Depress "B" switch to retract the cylinder. ZPE-45SVG-8A pump allows stopping of the cylinder, but can not hold pressure. ZPE-45SVG-8H has all ports open solenoid valve.

Maintenance

Hydraulic Oil

Use only ZINKO hydraulic oil or an approved high grade oil (ISO #32, viscosity: 32 cSt @40° C) with these pumps.

Oil Temperature

Aptitude temperature for use of hydraulic oil is maximum 55° C. If the color of the temperature seal attached to the tank has changed and indicated "55", an unacceptable rise in oil temperature has occurred. STOP WORKING IMMEDIATELY to decrease the oil's temperature. Installation of an oil cooler may be appropriate.

Zinko Hydraulic Jack

Model: ZPE-73HS Series

Oil Exchange

CAUTION The frequency of oil change depends upon general working conditions, severity of use, and overall cleanliness. 300 hours (working time) of use or about 3 months is considered as a standard change interval. Periodically compare samples of the reservoir oil with new oil. Inspect oil color for contaminants or differences.

Remove oil feed plug and tilt the pump to drain out old oil. Be careful that impurities such as dust do not enter into the reservoir and that new oil is filled up to the gauge level mark indicated in the pump. Precautions for oil change are:

- Retract all cylinders fully to the return position.
- Do not fill with even a small quantity or replenish with different kinds of oil.
- Be careful that impurities or foreign matter do not enter into new oil.

Oil Safety Notes

WARNING If oil should accidentally get in your eyes, flush eyes thoroughly with clean water and consult a doctor immediately. In case oil enters into an open wound, wash it away with soapy water and quickly consult a doctor.

Pressure and Piping

- WARNING** **Composition of hydraulic equipment system.** When a pump, high pressure hose(s), cylinder, valve, or coupling(s) are connected together, always check product limitations regarding pressure ratings and load capacities. The system operating pressure must not exceed the pressure rating of the lowest rated component in the system.
- Pressure gauges.** Always install or prepare a pressure gauge in-line from the pump in order to monitor pressure.
- CAUTION** **Piping.** Use wrapping of Teflon tape on hose fittings, valves and couplers. Make sure all hose connections are tight - use proper tools to tighten connections with reference to the following table.
DO NOT OVER TIGHTEN CONNECTIONS.

NPT, PT SIZES	TIGHTENING TORQUE N-m (kgf-m)
1/8"	13-14 (1.3-1.4)
1/4"	30-40 (3.0-4.0)
3/8"	60-70 (6.0-7.0)
1/2"	100-110 (10.0-11.0)

*Make sure that tape does not shed into the hydraulic system causing damage. Trim loose ends.

High Pressure Hoses

WARNING **Hose Installation.** Install hoses leaving oil in the reservoir because high pressure hoses expand and contract more or less when full pressure is applied. Be careful that the hoses do not rub against other solid materials. Never allow the hoses to kink, twist, curl or bend so tightly that oil flow within hoses are blocked or restricted. **DO NOT CLAMP THE HOSES.** Clamping the hoses can cause problems.

Hose Handling

DANGER Never drop heavy objects on or against the hoses. This can cause bursting of the hoses resulting in serious accident or injury. Do not subject the hoses to any potential hazard (fire, extreme heat or cold, heavy impact, or sharp surfaces), which may rupture or weaken the hoses. Never pull hoses to move or lift equipment connected with hoses.

Should a hose ever burst or rupture, **STOP OPERATING THE PUMP IMMEDIATELY** before attempting to remedy the situation. Never attempt to grasp a leaking hose under pressure with your hands. The force of the escaping hydraulic fluid could cause serious permanent injury.

Quick Couplers

Connections

Make sure that all couplers are connected properly. Incomplete coupling connections might cause partial or complete blockage of oil flow resulting in trouble of hydraulic system.

Handling

WARNING If the coupler becomes damaged, stop operating the pump. The damaged coupler can cause a serious accident. **DO NOT DISCONNECT COUPLER SETS,** they are under pressure.

Bleeding Air From the System

CAUTION In case a new cylinder and/or a hose is connected with the pump or hydraulic oil is exchanged, air may accumulate in the hydraulic system. This air will prevent the pump from delivering oil or cause the cylinder to respond in an unstable or slow manner. Be careful with air accumulation in the system. To remove air:

- The cylinder(s) must be positioned on their side with the couplers located upward.
- Remove any load from the cylinder(s) and cycle the hydraulic system through several cycles (fully extend and retract the cylinders) or intermittently for 2 to 3 minutes.

Zinko Hydraulic Jack

Model: ZPE-73HS Series

Bleeding Air From the System

- CAUTION** In case a new cylinder and/or a hose is connected with the pump or hydraulic oil is exchanged, air may accumulate in the hydraulic system. This air will prevent the pump from delivering oil or cause the cylinder to respond in an unstable or slow manner. Be careful with air accumulation in the system. To remove air:
- The cylinder(s) must be positioned on their side with the couplers located upward.
 - Remove any load from the cylinder(s) and cycle the hydraulic system through several cycles (fully extend and retract the cylinders) or intermittently for 2 to 3 minutes.

Carbon Brushes

WARNING Always check the wearing condition of the carbon brushes. When the carbon brushes have been worn down and replacing them is necessary, the motor will stop automatically. Replace when a brush has been worn down to 6mm in length as shown below, or working time of the motor is 500 hours or more (NOTE: Carbon brush replacement times may depending on the conditions of use). Use only **ZINKO** approved brushes with these pumps to extend the life of the unit(s). When they have been worn down the spring exerts insufficient pressure to hold brush against the commutator.

How To Change

- Disconnect the power supply.
- Remove rubber caps on two places and loosen.
- Remove fitting screws inside with a screwdriver so the carbon brush can be taken out.
- Replace brushes with new ones and reattach the screws and rubber caps.

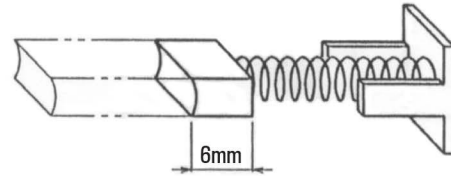

Relief Valve Adjustment

Range of standard pressure adjustment available is from 58.8 to 68.6MPa. Loosen lock screw on the high pressure relief valve and turn the adjusting screw a few turns counterclockwise to decrease pressure setting to a lower desired pressure. Clockwise rotation of the adjusting screw will increase pressure. After setting pressure, replace the lock screw. NOTE: A different kind of spring is needed to adjust and set at a lower pressure than standard. Consult a **ZINKO** authorized dealer.

WARRANTY

Warranty period is for one year from purchase.

All **ZINKO** products and parts, with the exception mentioned below, are warranted against defects in materials and workmanship, which results in damage to products and parts. This warranty shall cover repair and/or replacement of the products or components/parts free of charge. To qualify for warranty consideration, return the **ZINKO** product, freight prepaid, to a **ZINKO** service facility.

Warranty Exceptions

No warranty claim will be accepted for damage or breakdown arising for any of the following reasons:

"Abuse or improper use, fair wear and tear, faulty or negligent operation, improper storage, chemical/electrical influences or climatic or other effects which can not be related specially to faults in manufacture."

No liability is accepted for packing seals, springs, and/or the like, and the following:

- Alterations or remodeling on the products undertaken by the purchasers without any prior notice and agreement to **ZINKO**.
- Severe and very highly frequent use, deviating from product specifications.
- Damage due to faulty installation or assembly by purchasers or third parties.
- Damage from natural disaster.
- Damage from such accidents as fire, submersion, dropping, etc.

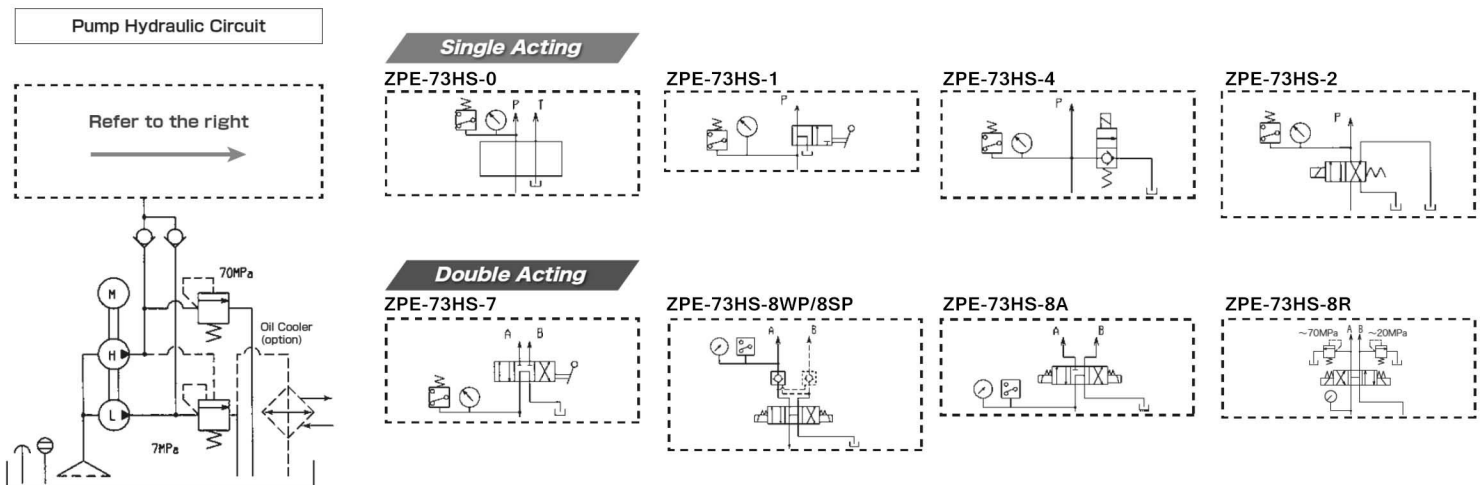

Zinko Hydraulic Jack

Model: ZPE-73HS Series

Troubleshooting

PROBLEM	CAUSE	SOLUTION
Motor Does Not Run.  WARNING Disconnect Power Supply Before Disassembly or Repair.	<ol style="list-style-type: none">1. No supply voltage.2. Broken lead wire or defective power cord plug.3. Defective switches.4. Worn carbon brushes.5. Defective motor.6. Defective remote switch.7. Unit is not plugged in.	<ol style="list-style-type: none">1. Check line voltage.2. Replace defective part.3. Check switches.4. Replace carbon brushes (see page 4).5. Repair or replace motor.6. Repair or replace switch.7. Plug in unit.
Abnormal Noise From Motor.	<ol style="list-style-type: none">1. Damage to pump or motor.2. Damage of ball bearings, etc.	<ol style="list-style-type: none">1. Repair or replace unit.2. Replace ball bearings.
Motor Runs, But Cylinders Do Not Advance or Retract.	<ol style="list-style-type: none">1. Damage of release valve.2. Oil level is too low.3. Oil feeding plug is closed.4. Air in system.5. Filter plugged or dirt in the pump.5. Damage of the pump body.6. Relief valve out of adjustment.7. Damage or out of adjustment relief valve.	<ol style="list-style-type: none">1. Repair or replace release valve.2. Fill reservoir to 1/2 of level gauge with all cylinders retracted.3. Open oil feeding plug.4. Bleed the system (see page 4).5. Pump filter should be dismantled and cleaned if necessary.5. Repair pump.6. Readjust as needed.7. Repair or readjust as needed.
Cylinders Work, But Full Pressure is Not Reached.	<ol style="list-style-type: none">1. Damage of release valve.2. Air in the system.3. Damage of the pump body.4. Lowering of set pressure.	<ol style="list-style-type: none">1. Repair or replace release valve.2. Bleed the system (see page 4).3. Repair pump.4. Readjust set pressure.
Cylinders Work, But Speed is Too Slow or Erratic.	<ol style="list-style-type: none">1. Damage of release valve.2. Air in the system.3. Unacceptable rise in oil temperature.4. Damage of the pump body.	<ol style="list-style-type: none">1. Repair or replace release valve.2. Bleed the system (see page 4).3. Stop operation or install oil cooler.4. Repair pump.
Cylinders Do Not Retract.	<ol style="list-style-type: none">1. Damage of release valve.2. Damaged cylinder return springs or damaged quick couplers.3. Improper contact of operation switch for solenoid valve.	<ol style="list-style-type: none">1. Repair or replace release valve.2. Repair or replace springs or couplers.3. Repair or replace operation switch.
Leaking Oil.	<ol style="list-style-type: none">1. Damaged seals, seats, or steel balls.	<ol style="list-style-type: none">1. Replace damaged component(s).
Short Circuit.	<ol style="list-style-type: none">1. Damaged cords.2. Bad insulation of electric parts.	<ol style="list-style-type: none">1. Replace damaged component(s).2. Locate and replace damaged component(s).

If the above procedures do not correct the problem, contact your nearest **ZINKO** service facility. When submitting any jack or equipment to be repaired, be sure to state the nature of the problem and indicate whether an estimate of the repair cost is needed.



ZINKO HYDRAULIC JACK

PO Box 4903, Ontario, CA 91761

Toll Free: 1-800-579-8088

www.zinkojack.com

Phone: (909) 230-4100

Fax: (909) 230-4137